



Crane scales

[PCE-CS 3000N / PCE-CS 5000N]

PCE Americas Inc.
711 Commerce Way
Suite 8
Jupiter
FL-33458
USA
From outside US: +1
Tel: (561) 320-9162
Fax: (561) 320-9176
info@pce-americas.com

PCE Instruments UK Ltd.
Units 12/13
Southpoint Business Park
Ensign way
Hampshire / Southampton
United Kingdom, SO31 4RF
From outside UK: +44
Tel: (0) 2380 98703 0
Fax: (0) 2380 98703 9
info@pce-instruments.com

EN

www.pce-instruments.com/english
www.pce-instruments.com

Crane Scale PCE-CS 3000N / 5000 N

Reasonably priced crane scale for weight range up to 5000 kg / resolution above 0.5 kg / operation on battery / rotary hook and shackle / aluminum enclosure under pressure

The crane scale is an advanced wireless crane scale of our PCE-CS HD series. The crane scale combines the safety and comfort of having a remote, wireless control and a hook, which allows easy and flexible operation. The PCE crane scale is especially suitable for rough conditions in different industries, as well as for a wide variety of other applications due to a solid aluminum enclosure. Several functions, such as the tare function, zero point, summation, auto off facilitate and automate the operation of the crane scale. The crane scale features a fixed shackle at the top as well as a rotary hook with a safety mechanism for the load at the bottom.

- Measurement range up to 5,000 kg
- Resolution above 0.5 kg
- Large LED display
- Digit Height 35 mm
- Aluminum enclosure
- Operation on battery up to 200 hrs.
- Summation function
- Hook with whirl (rotatable)
- Incl. shackle (solid)
- Incl. remote control

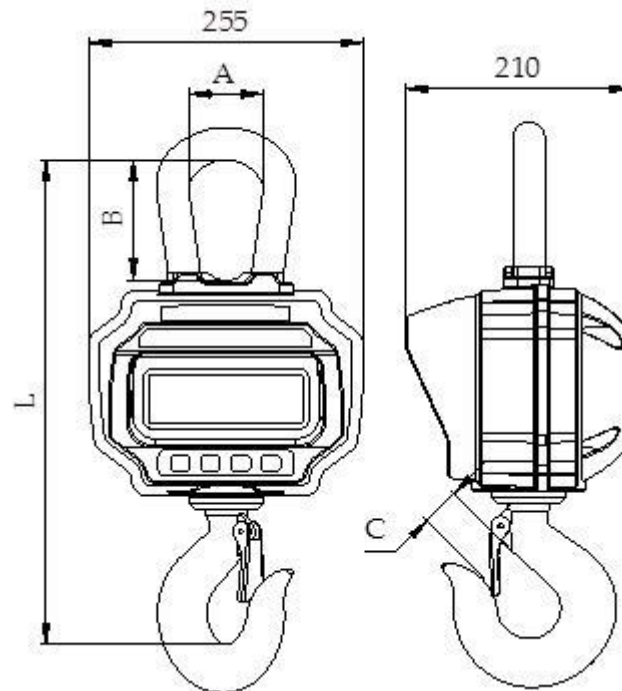

Edition	A	B	C	L	Weight
PCE-CS 3000N	68 mm	112 mm	33 mm	420 mm	approx. 11 kg
PCE-CS 5000N	68 mm	112 mm	36 mm	450 mm	approx. 12.5 kg

Technical specifications of the Crane Scale PCE-CS 3000N / 5000N

Model	Weighing range	Resolution	Uncertainty in measurement
PCE-CS 3000N	3,000 kg / 3 t	0.5 kg	± 2 kg
PCE-CS 5000N	5,000 kg / 5 t	1 kg	± 4 kg
Tare range		For whole measurement range	
Settling time		5 sec.	
Weighing units		kg / lb	
Enclosure		aluminum	
Display / Digit height		LED red / 35 mm	
Operational Temperature		-10 °C ... +40 °C	
Power Source		6 V - 4 Ah internal battery / BAT-6V-4.5Ah	
Battery lifetime		max. 200 hrs.	

Delivery content of the Crane Scale PCE-CS 3000N

1 x Crane Scale PCE-CS 3000N / 5000N, 1 x Internal battery (rechargeable), 1 x Charger, 1 x Remote Control, 1 x Instruction Manual